



Filtering System

Specifications

- ✓ For dry grinding with Bohle twin belt grinding machines
- ✓ Sturdy and powerful
- ✓ Low operating expenses
- ✓ Filter housing can be tilted for easy dust disposal
- ✓ Fully automatic cleaning of permanent filter cartridges (dust class M) during the extraction process
- ✓ Easily movable with 6 castor rollers



Filtering System for Twin Belt

Technical Data

Filtering System

	Filtering system DUSTOMAT-47
Nominal air volume - m ³ /h	1330
max. low pressure at inlet PA	3800
Filter surface in m ²	9.6
Dimensions (WxDxH mm)	1830x782x2040
Power connection	3 kW, 400 V, 50 Hz, 3NPE
Cleansing	automatic
Intake diameter in mm	140
Filter material	Dust class "M"
Weight in kg	215
Art. no.	BO 89.205

Dimensions:

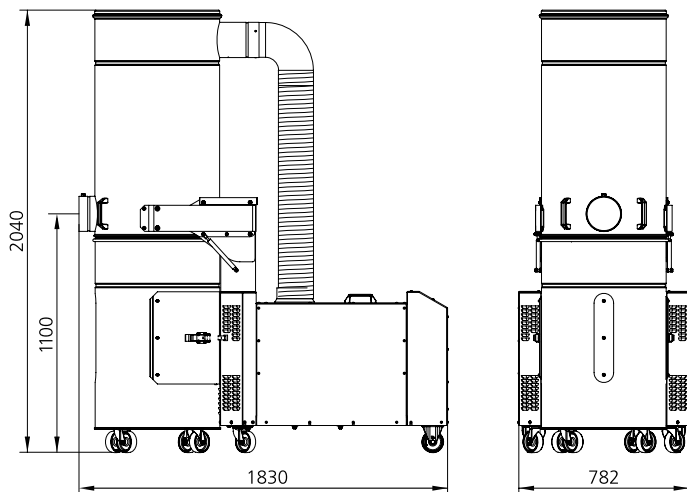

Subject to changes in line with technical progress!